

Confocal Raman / Fluorescence Microscope

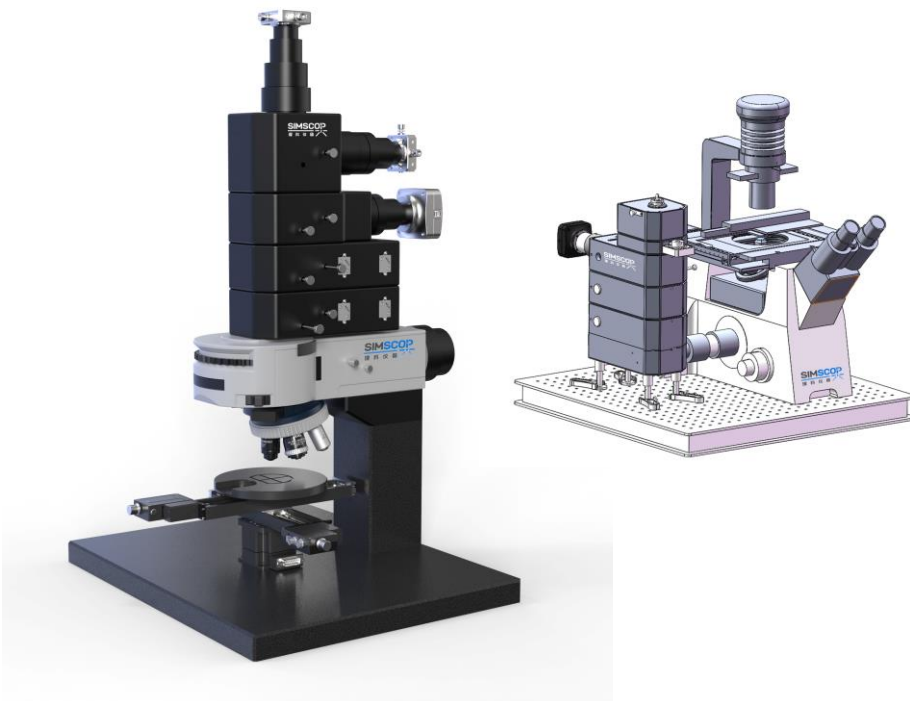

2024 V1

For customized projects please Contact us:

info@simtrum.com

Confocal Raman Microscopy (CRM) combines Raman spectroscopy and confocal microscopy techniques. This advanced analytical instrument utilizes Raman scattering to obtain Raman information from samples while achieving high spatial resolution imaging through the confocal system.

SIMSCOP's Raman microscope series employs a modular design concept, featuring numerous external interfaces. By integrating different modules, the system achieves multi-functionality, greatly enhancing flexibility and expandability. The system not only enables Raman spectra and image acquisition from samples but also supports 3D confocal imaging acquisition with the SIMSCOP confocal module. Users can flexibly connect external laser sources, spectrometers, and various sample stages according to experimental or application needs to achieve multiple functionalities.

Features

- **Upright and inverted microscope structures** Adapts to various experimental needs.
- **Multi-wavelength lasers** Supports 405nm, 532nm, 638nm, 785nm, and 1064nm, meeting diverse experimental requirements.
- **Modular design** Connects external laser sources and spectrometers, easily upgradable.
- **Customizable sample stages** Suitable for stretching, high/low-temperature, in-situ, and vacuum stages.
- **Electric / Manual stages** Offers high precision with various configurations.
- **Non-coaxial optical measurement support** Broadens measurement options and flexibility.

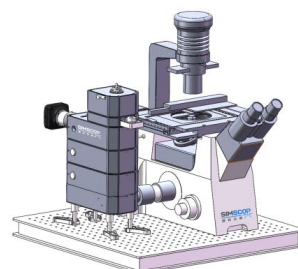

Raman Confocal Inverted Microscope

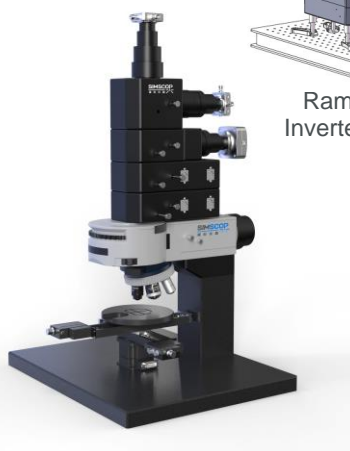

Dual-Optical Raman & PL Confocal Upright Microscope

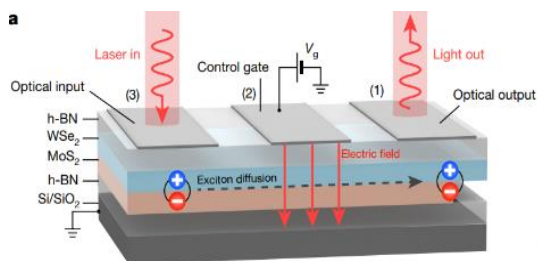
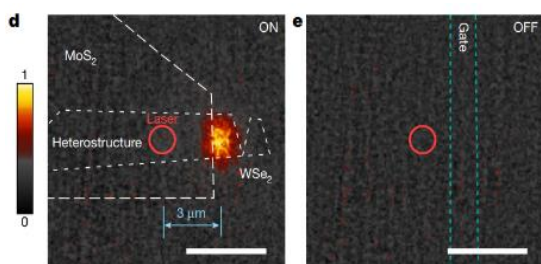

Non-coaxial measurement

Laser excitation on point A
Raman detection on point B

High Flexibility in Multiple Microscope Modes

- Supports wide-field Raman microscopy imaging
- Supports confocal Raman microscopy imaging
- Supports multi-channel wide-field fluorescence microscopy imaging
- Supports multi-channel photoluminescence microscopy imaging

Applications

- Biology and Life Sciences
- Material Science
- Graphene and Carbon Nanotubes
- Nanomaterials
- Catalysts
- Semiconductors
- Process Contamination Analysis
- Pharmaceutical Quality Control

Specifications

Model	SIMSCOP-RAMAN-S1	SIMSCOP-RAMAN-S2
Laser	Single-channel laser: 1 channel Wavelengths: 532 nm, 638 nm, 785 nm optional Power: 100mW, Linewidth: 0.003nm, Power stability: 1%	Multi-channel laser: Up to 5 channels Wavelengths: 405nm, 532 nm, 638 nm, 785 nm, 1064 nm Power: 100mW, Linewidth: 0.001nm, Power stability: 1% Near-infrared spectrum support
Compatible Spectrometers	Fiber spectrometer / Third-party spectrograph/monochromator (Horiba, Andor, etc.)	
Spectral Resolution	Fiber spectrometer: $\leq 4\text{cm}^{-1}$ / Third-party spectrograph/monochromator: $\leq 1.23\text{cm}^{-1}$	
Spectral Range	50 cm^{-1} – 15,000 cm^{-1} (customizable)	
Fiber Spectrometer Detector Options	Option 1: M Series - Hamamatsu S10420	2048 x 64 pixels, Cooled BSI
	Option 2: MC Series - Hamamatsu S7031-1006S	1044 x 64 pixels, Cooled BSI CCD
	Option 3: HiNA Series - E2V	2000 x 264 Pixel -70°C Cooled BSI CCD Dark Current <0.001e⁻/pixel/s
Wide-field Camera	CMOS back-illuminated camera 15FPS@5440x3648; 50FPS@2736x1824; 60FPS@1824x1216	
Confocal Mode	Manual pinhole	Electric continuously variable speed pinhole
Confocal Imaging Resolution	~200nm @100x objective	
Spot Size	~1um @50x	
Sample Stage	XY electric (manual optional), Z manual (upgradeable to electric), Repeat positioning accuracy: $\pm 0.25\mu\text{m}$	XYZ electric, Repeat positioning accuracy: $\pm 0.25\mu\text{m}$
Travel Distance	XY: 50mm*50mm, Z: 150mm (customizable)	
Load Capacity	10KG	
Sample Stage Compatibility	Compatible with standard stretching stages, high temperature or cryo stages, in-situ stages, and vacuum stages	
Microscope Compatibility	Compatible with upright/inverted microscopes	
Objectives (Optional)	Long working distance 10X objective NA: ≥ 0.25 ; WD: $\geq 30\text{mm}$; Resolution: $\leq 1\mu\text{m}$ Long working distance 20X objective NA: ≥ 0.40 ; WD: $\geq 20\text{mm}$; Resolution: $\leq 0.80\mu\text{m}$ Long working distance 50X objective NA: ≥ 0.50 ; WD: $\geq 10\text{mm}$; Resolution: $\leq 0.60\mu\text{m}$	
Software	Standard Software Features	Advanced Features 1.Z-axis Autofocus 2.Confocal Adaptive Pinhole 3.3D Scanning Imaging 4.Advance Raman Spectroscopy data analysis

Upright Confocal Raman / Fluorescence Microscope - Appearance & Optical Path

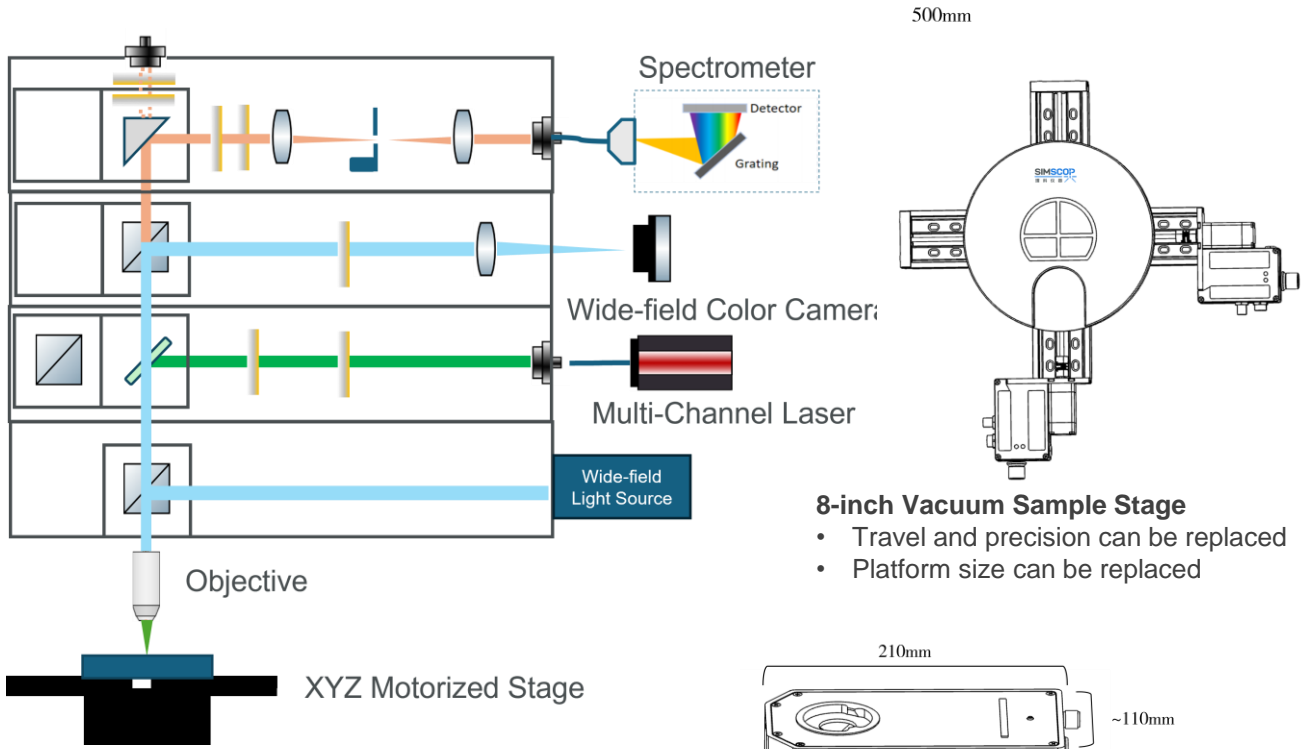
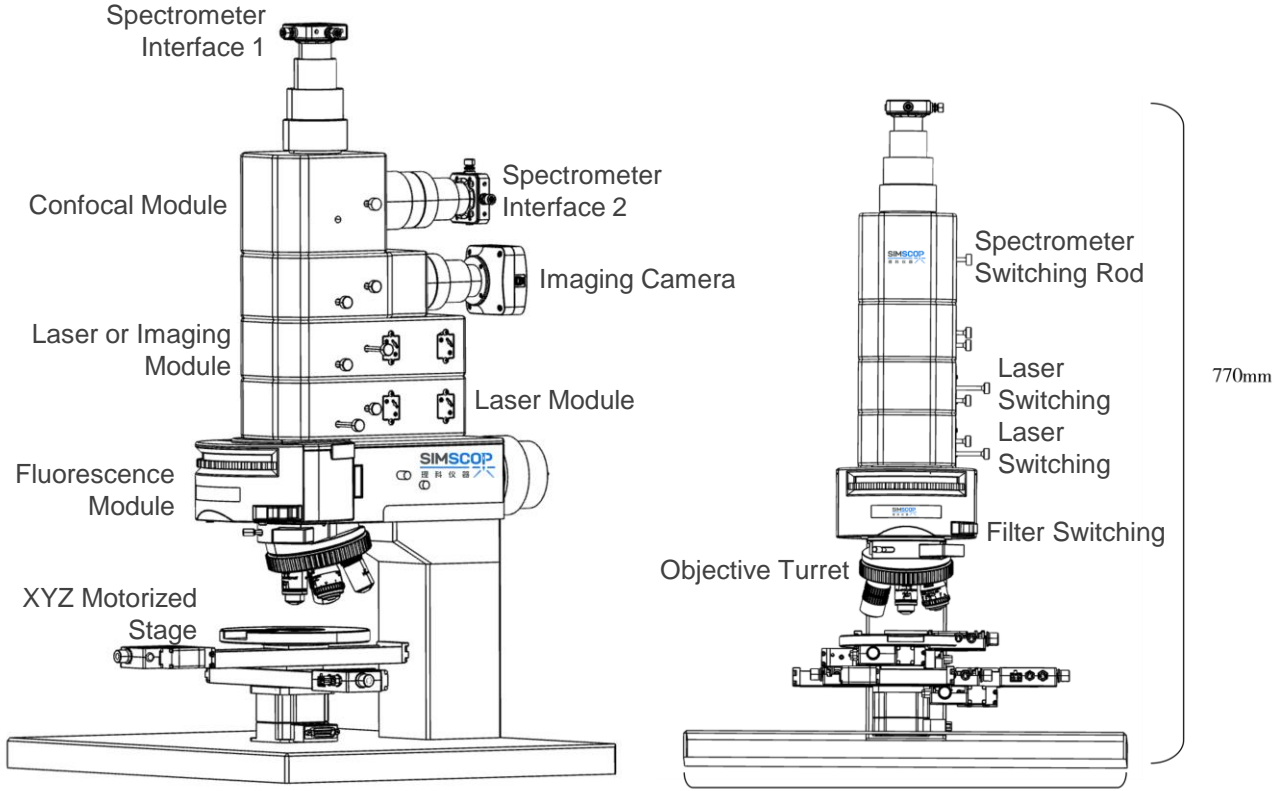

Optical Path

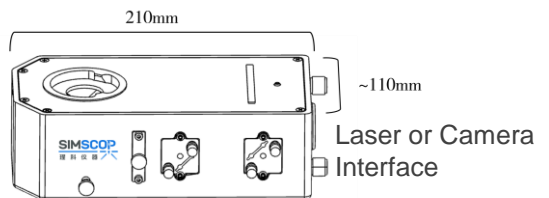

Detachable Optical Path Module

- 8-inch Vacuum Sample Stage**
- Travel and precision can be replaced
 - Platform size can be replaced

Inverted Confocal Raman / Fluorescence Microscope - Appearance & Optical Path

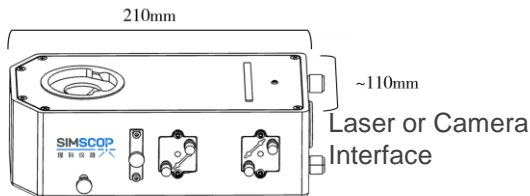
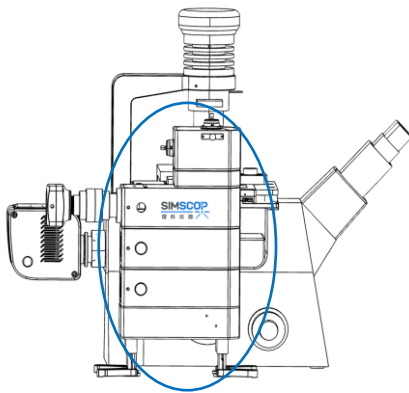
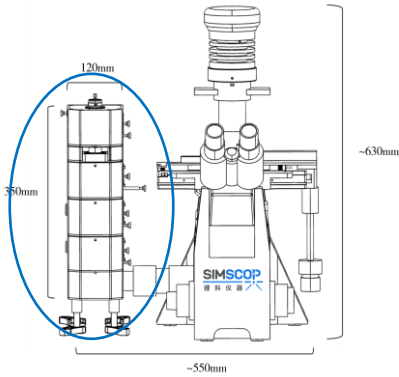

Detachable Optical Path Module

Spectrometer Interface 1

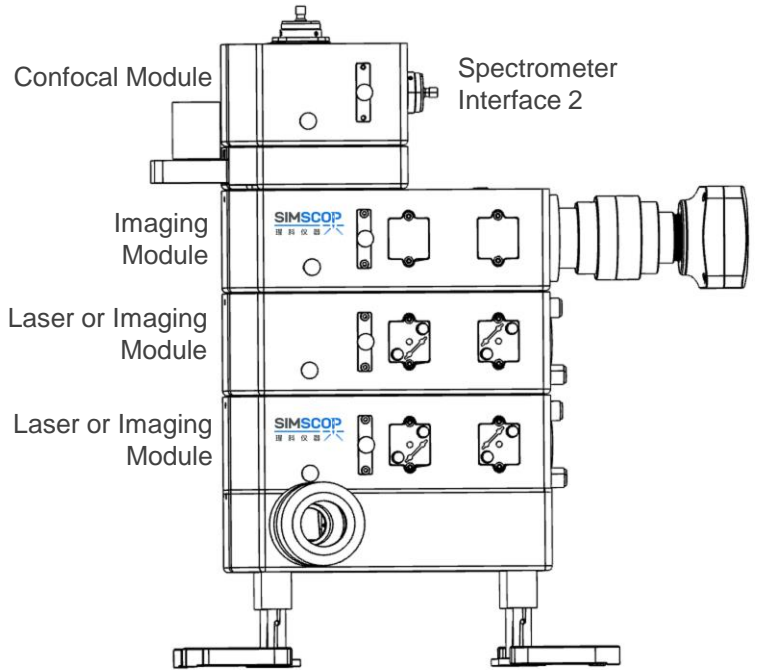

Optimized Multi-Fluorescence Channels for Biological Users

- Supports multi-channel laser sources or imaging cameras
- Allows the use of multiple cameras for fluorescence imaging and image integration
- Simultaneously collects single-point spectra/Raman signals while acquiring fluorescence images
- Users can freely add multiple modules

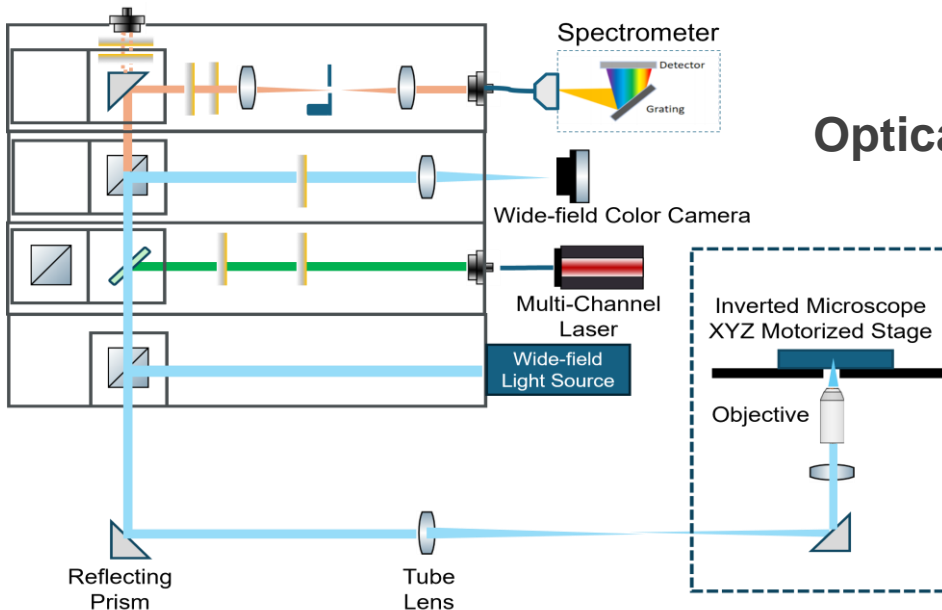

Optical Path

Software UI

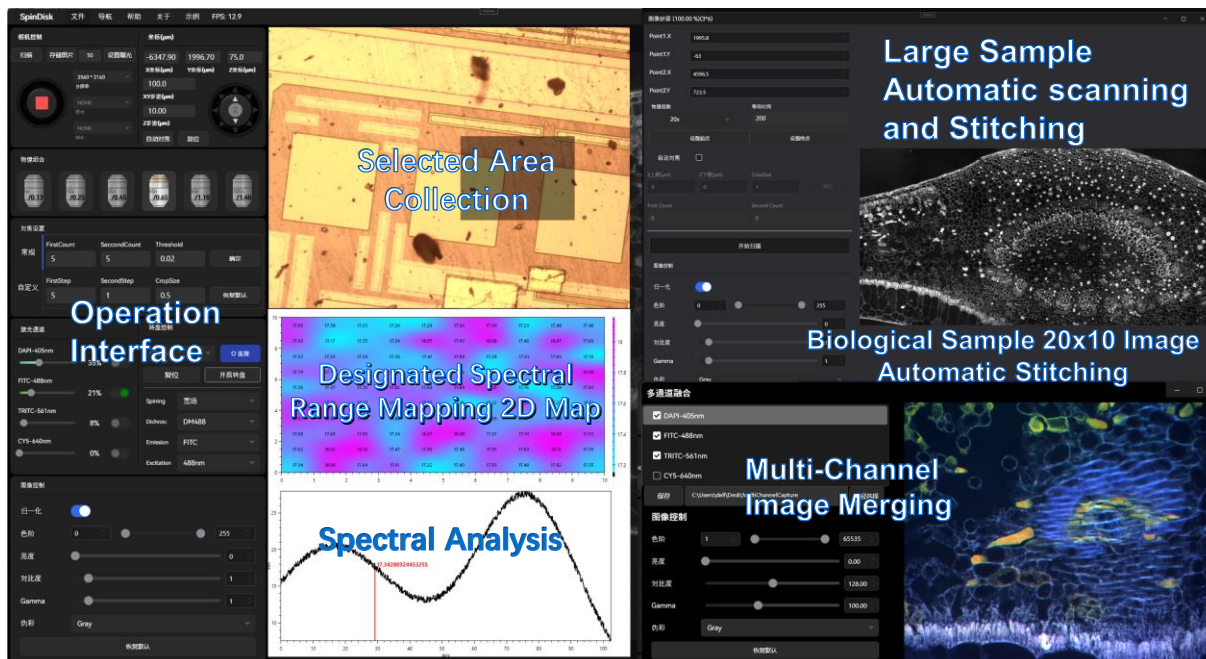

Core Software Features

1. Raman Confocal Image Acquisition Software

- Supports real-time control and synchronization of hardware devices like motorized stages, lasers, cameras, and spectrometers.
- Allows flexible setting of Raman spectroscopy parameters, such as exposure time, averaging, and wavelength range, to meet different experimental needs.

2. Confocal 3D Scanning and Raman Mapping Function

- Users can define the scanning range and points on the XY plane and achieve automated scanning through motorized stages.
- The software records Raman spectral data at each point, supports selecting Raman peaks to generate Raman characteristic maps, facilitating the analysis and comparison of the sample's Raman characteristics.
- Supports point, line, and area 3D tomography imaging, and 3D image stitching.
- Provides intuitive 3D video images and Raman spectra display, helping users fully understand the structural and chemical characteristics of the samples.

3. Professional Raman Spectroscopy Acquisition and Processing Software

- Includes complete instrument control, data acquisition, and processing functions, such as Raman peak matching, automatic fluorescence background correction, auto exposure, averaging, noise reduction, and filtering.
- Supports advanced data analysis functions like FWHM measurement and signal integration, providing comprehensive data processing solutions.

4. Third-Party Spectrometer Support

- The software supports common third-party spectrometers, facilitating microscope upgrades for existing spectrograph / monochromator.

Applications

Singapore IMRE Ultra-Low Temperature Raman System

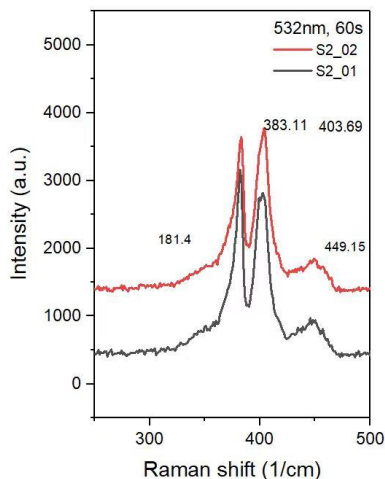
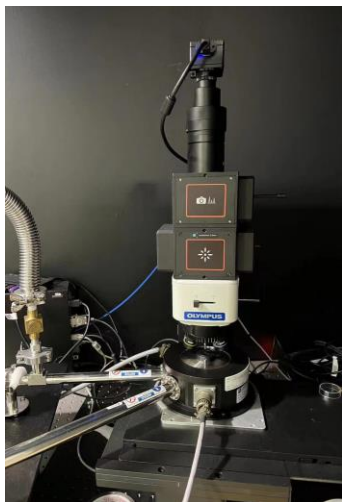

IMRE Raman Test Results,
532nm Raman

Sun Yat-sen University Dual Optical Path PL Test System

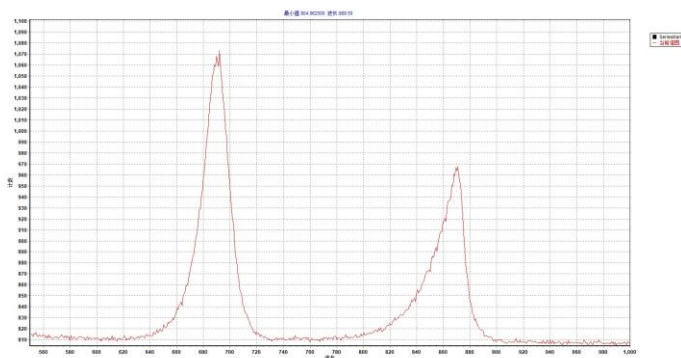
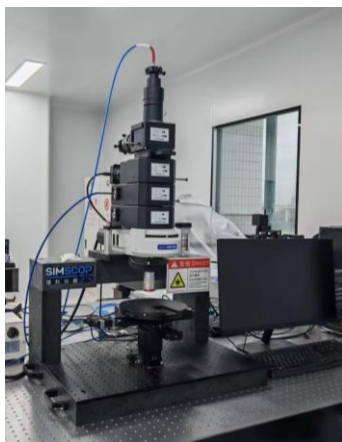

Sun Yat-sen University PL Test Results

Get the Perfect Custom Combination! Contact us now for Various Sample Stage:



High Temperature
Stage
1200 ~ 1800 °C



Electrical Probe
Temperature Stage
-190 ~ 600 °C



In-situ Tensile
Heating & Cryo stage

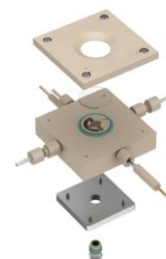

Electrochemical
In-situ Cell